



PRIMARY SUMP PUMP BACKUP POWER SYSTEM

INSTRUCTION AND OPERATING MANUAL



MODELS: BU-1500 / BU-2000

GENERAL INFORMATION

To ensure safe and reliable operation, please carefully read this service and installation manual in its entirety before installing and/or using this product. Reasonable care and safe methods in according with sound plumbing practices should be strictly adhered to. Before installation, refer to and understand all relevant local plumbing and electrical codes.

DO NOT THROW AWAY THIS MANUAL. Keep it in a safe place so that you may refer to it for periodic service and maintenance.

Always disconnect the power before servicing this product. Failure to do so may result in serious injury or death. Consult with a qualified electrician if you are unsure of the power source or cannot determine whether power has been properly disconnected.

SAFETY INFORMATION

Please review and follow the safety information listed below.

WARNING

- Risk of electric shock. Always disconnect power before servicing.
- Not to be used as a grid-tie inverter.
- Do not make any electrical connections while standing on a wet surface or with wet hands.
- Electrical connections and wiring for a pump installation should only be made by qualified personnel.
- This equipment is equipped with an approved 3-conductor cord and 3-prong grounding-type plug, and is only for use with a grounded 110/120VAC receptacle.
- For proper and safe operation, the temperature range where this unit is to be installed is 14°F to 120°F and well ventilated. Avoid installing in direct sunlight.
- DO NOT bypass grounding wires or remove the ground prong from the plug.
- DO NOT use an extension cord.
- NEVER lift this product by the electrical power cord.
- NEVER attempt to open or service this unit.
- DO NOT store anything on top of this unit. This surfaces of this unit may become hot to the touch, particularly during periods of high demand / use.

PERFORMANCE

The Primary Sump Pump Backup Power System will convert DC power from a 12VDC Deep Cycle Battery to AC power. When the Primary Sump Pump Backup Power System is inverting, the output waveform is a pure sine wave.

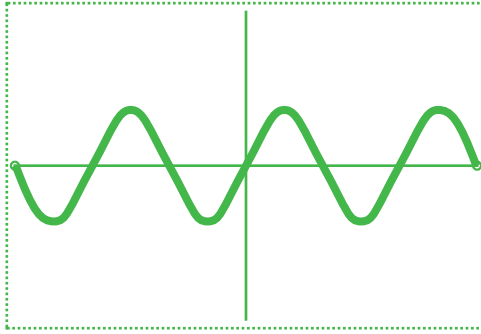

SPECIFICATIONS

⚠ ATTENTION

The Primary Sump Pump Backup Power System is grounded via a PCB Ground Plane. This grounding technique is not detected by GFCI testing devices.

Model	BU-1500	BU-2000
Rated Power	1500W	2000W
Surge	3750W	4000W
Input Voltage	12VDC	
Output Voltage	120VAC	
USB Port	5VAC	
Frequency	50/60Hz	
Output Wave	Pure Sine Wave	
Soft Start	Yes	
Cooling Method	Intelligent Cooling Fan	
Protection	Battery Low Voltage/Over Voltage, Over Load, Over Temperature, Short Circuit	
Working Temp.	14°F to 120°F	

OPERATION

When 120VAC household power is available to the Primary Sump Pump Backup Power System, household power is directly routed through to both of the outlet receptacles. When the unit is powered ON (the "Power" indicator LED will be BLUE), the unit will charge the connected 12VDC Deep Cycle Battery if needed. The "Charge" status indicator LED will be RED while charging the battery. The "Full" status indicator LED will be BLUE once the battery is fully charged. When AC power is lost, the Primary Sump Pump Backup Power System will automatically activate and convert the 12VDC input to 120 VAC pure sine wave output at both of the outlet receptacles.

The "Fault" status indicator LED will turn RED when the Primary Sump Pump Backup Power System is overloaded, overheating, receiving low household voltage, or has a short circuit.

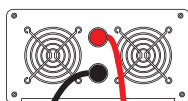
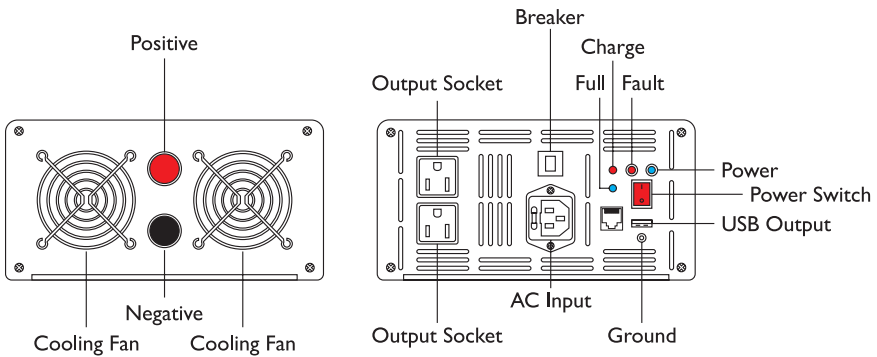

Multiple 12VDC Deep Cycle Batteries may be connected in parallel. A PumpSpy Maintenance Free AGM Deep Cycle Battery is recommended.

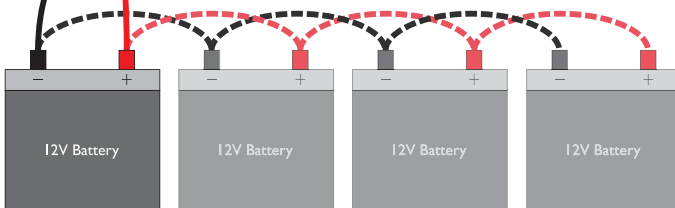

INSTALLATION

1. Ensure the Backup Power System is powered off and disconnected from both AC and DC power.
2. Remove the Pre-Charge Kit from the positive (RED) battery lead ring. Open the Pre-Charge Kit and wrap one of the resistor wires around the positive (RED) battery lead ring.
3. Using the end not connected to the resistor wire, connect the positive (RED) battery lead to the positive (RED) terminal on the Backup Power System. Tighten the terminal retention knob securely by hand. Do not use any tools to tighten as this may break the retention knob.
4. Connect the negative (BLACK) battery lead to the negative (BLACK) terminal on the Backup Power System. Tighten the terminal retention knob securely by hand. Do not use any tools to tighten as this may break the retention knob.
5. Connect the negative (BLACK) battery lead to the negative (BLACK) terminal on the 12VDC Deep Cycle Battery. Secure the connection per the battery manufacturer's recommendation.
6. Touch and hold the free end of the resistor wire to the positive (Red) terminal on the battery for 3 seconds. Completely remove the resistor wire from the positive (RED) battery lead ring.
7. Connect the positive (RED) battery lead to the positive (RED) terminal on the 12VDC Deep Cycle Battery. Secure the connection per the battery manufacturer's recommendation.
8. Plug the Backup Power System into a 120VAC outlet.
9. Confirm that the power switch is in the OFF position. Plug your sump pump(s) into either of the two 120VAC outlet receptacles.
10. Flip the power switch into the ON position.
11. Allow the Backup Power System to charge the battery until the "Full" status indicator LED is BLUE.
12. Test the AC power functionality by manually activating the connected sump pump(s).
13. Test the DC power functionality by unplugging the Backup Power System from the 120VAC outlet to simulate a power outage. Then, manually activate the connected sump pump(s).
14. Reconnect the Backup Power System to a 120VAC outlet.

ATTENTION

An optional grounding wire is included to connect the Primary Sump Pump Backup Power System's case to the mounted wall.

TROUBLESHOOTING

WARNING

Always disconnect the power unit from power sources before handling. This guide is designed to help identify reasons for potential operating problems. It is not a service guide. Dismantling of the Primary Sump Pump Backup Power System voids warranty. Servicing of power unit should be referred to PumpSpy.

“FAULT” STATUS INDICATOR LED IS RED

A RED “Fault” status indicator LED is a sign of system trouble. Make sure that the cooling fans are clear of any obstacles and debris. Check your household voltage to make sure it is at least 110VAC. If you are using both outlets, make sure the combined current draw of the connected devices does not exceed 16.6 Amps on a continuous basis. The Power Unit will automatically shut down, an alarm will sound, and the “Fault” status indicator LED will turn RED when the load exceeds 16.6 Amps.

LOW VOLTAGE ALARM

When the Battery voltage drops below 10VDC, an audible alarm will sound to indicate that it needs to be recharged.

AC FUSE REPLACEMENT

To replace the AC fuse, remove the fuse panel shown in Figure 1. A flat-head screwdriver may be needed. The replacement fuse and the in-use fuse are both marked in Figure 2.

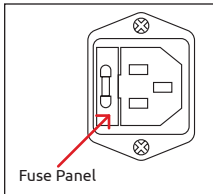

Figure 1

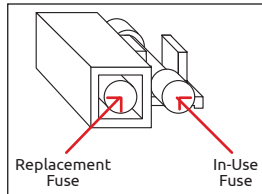

Figure 2

MAINTENANCE

The Primary Sump Pump Backup System should be checked frequently for debris and/or build up on the cooling fans which may interfere with proper flow to cool the unit during operation. The cooling fans should be cleaned with a vacuum to remove any buildup at least every 3 months, or more frequently if the unit is mounted in an area where excess dust or debris may be present.

Deep Cycle Batteries generally last between 3 to 5 years in a sump pump backup installation. It is recommended that the battery is tested every 6 months to ensure it is ready for service.

LIMITED THREE-YEAR WARRANTY

WHAT THIS WARRANTY COVERS

When used and maintained in normal use and in accordance with the Installation and Operating Instructions, your PumpSpy® product is warranted against original defects in material and workmanship for a full three years from date of purchase (the “Warranty Period”). During the warranty period, PumpSpy will repair or replace at no cost to you, to correct such defects in products found upon examination by PumpSpy to be defective in materials or workmanship.

WHAT THIS WARRANTY DOES NOT COVER

This warranty does not cover use of the product in a non-residential application, improper installation and/or improper maintenance of the product, damage due to misuse, acts of God, nature, vandalism or other acts beyond the control of PumpSpy, owner’s acts or omissions, use outside the country in which the product was initially purchased and resales of the product by the original owner. This warranty does not cover pick up, delivery, transportation or house calls. However, if you mail your product to PumpSpy for warranty service, cost of shipping will be paid one way. This warranty does not cover products purchased from a party that is not an authorized retailer, dealer, or distributor of PumpSpy products.

OTHER IMPORTANT TERMS

This warranty is not transferable and may not be assigned. This warranty shall be governed and construed under the laws of the state of Michigan. The warranty period will not be extended by any replacement or repair performed under this warranty. THIS WARRANTY IS THE EXCLUSIVE WARRANTY AND REMEDY PROVIDED BY PumpSpy. ALL OTHER WARRANTIES, EXPRESSED OR IMPLIED, INCLUDING WARRANTIES OR MERCHANTABILITY OR FITNESS FOR PARTICULAR PURPOSE ARE DISCLAIMED. IN NO EVENT WILL PumpSpy BE LIABLE FOR ANY SPECIAL, INDIRECT, INCIDENTAL OR CONSEQUENTIAL DAMAGES OF ANY KIND OR NATURE TO OWNER OR ANY PARTY CLAIMING THROUGH OWNER WHETHER BASED IN CONTRACT, NEGLIGENCE, TORT OR STRICT PRODUCTS LIABILITY OR ARISING FROM ANY CAUSE WHATSOEVER. Some states do not allow for the exclusion of consequential damages, so the above exclusion may not apply to you. This warranty gives you specific rights. You may also have others that vary state to state.



2723 Kersten Ct.
Kalamazoo, MI 49048
1-833-PUMPSPY

www.PumpSpy.com

© 2023 PumpSpy. All Rights Reserved.

95353-03